

DESIGN NOTES

Simple, Efficient, All-in-One USB Power Management IC Solution

Design Note 1008

John Shannon

Introduction

Linear Technology offers a variety of devices that simplify converting power from a USB cable, but the LTC[®]3455 represents the highest level of functional integration yet achieved. The LTC3455 seamlessly manages power flow between an AC adapter, USB cable and Li-ion battery, while complying with USB power standards, all from a 4mm × 4mm QFN package. In addition, two high efficiency synchronous buck converters generate low voltage rails which most USB-powered peripherals require. The LTC3455 also provides power-on reset signals for the microprocessor, a Hot Swap[™] output for powering memory cards as well as an uncommitted gain block suitable for use as a low-battery comparator or an LDO controller. The PCB real estate required for the entire USB power control circuit and two DC/DC converters is only 225mm².

The simplified block diagram of the LTC3455 in Figure 1 shows the major components that allow the LTC3455 to accomplish multiple functions. The DC/DC conversion is

a relatively straightforward buck converter function. Each of the DC/DC converters takes as its input a voltage called V_{MAX} , which is derived from one of the three available power sources (explained below) and converts it to the desired output voltage. The DC/DC converters provided are high frequency, high efficiency synchronous converters with characteristics that are roughly equivalent to the LTC3405 and the LTC3406. V_{MAX} represents an intermediate voltage bus.

Operation with Wall Adapter Present

If the wall adapter is present, the intermediate V_{MAX} bus is powered regardless of other available power sources, providing power to both the DC/DC converters and the battery charger. The battery, if also present, is charged via the LTC3455's constant current, constant voltage, timer terminated, linear charger (similar in features and characteristics to the LTC4053).

Operation with No Wall Adapter Present, But Available USB Power

If the source of power is a USB input, then the USB power is switched through to V_{MAX} via a current limiting circuit in order to comply with USB current limits. The voltage at V_{MAX} is used to run both DC/DC converters. If the required load power is less than the available USB power, then the remaining power is used to simultaneously charge the battery. As the DC/DC load increases, the battery charge current decreases in such a way as to maintain USB input current compliance. Eventually, as the load power exceeds the available USB power, battery charging ceases and the battery begins to source supplemental power through the internal ideal diode into V_{MAX} . In this mode, some of the load current is provided from the available USB power, with the balance coming from the battery.

This intermediate bus power architecture has important benefits at the system level. In contrast with so-called

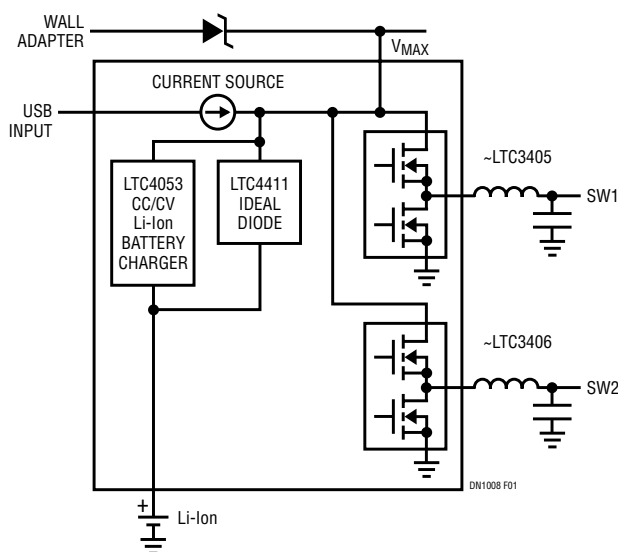

Figure 1. LTC3455 Simplified Block Diagram

LT, LTC and LT are registered trademarks of Linear Technology Corporation. Hot Swap is a trademark of Linear Technology Corporation.

“charger fed” systems in which the DC/DC loads are placed in parallel with the battery, this system is capable of running without a battery or with a fully discharged battery. Also, in a charger fed system, power is wasted by first linearly regulating the USB voltage down to the battery voltage. The benefits of the intermediate bus architecture are illustrated in Figure 3. An intermediate

bus voltage yields faster charging and lower heat dissipation than a charger-fed architecture.

Operation when Unplugged

When both the adapter and USB input are not present, the LTC3455 powers V_{MAX} through an ideal diode connected to the Li-ion cell.

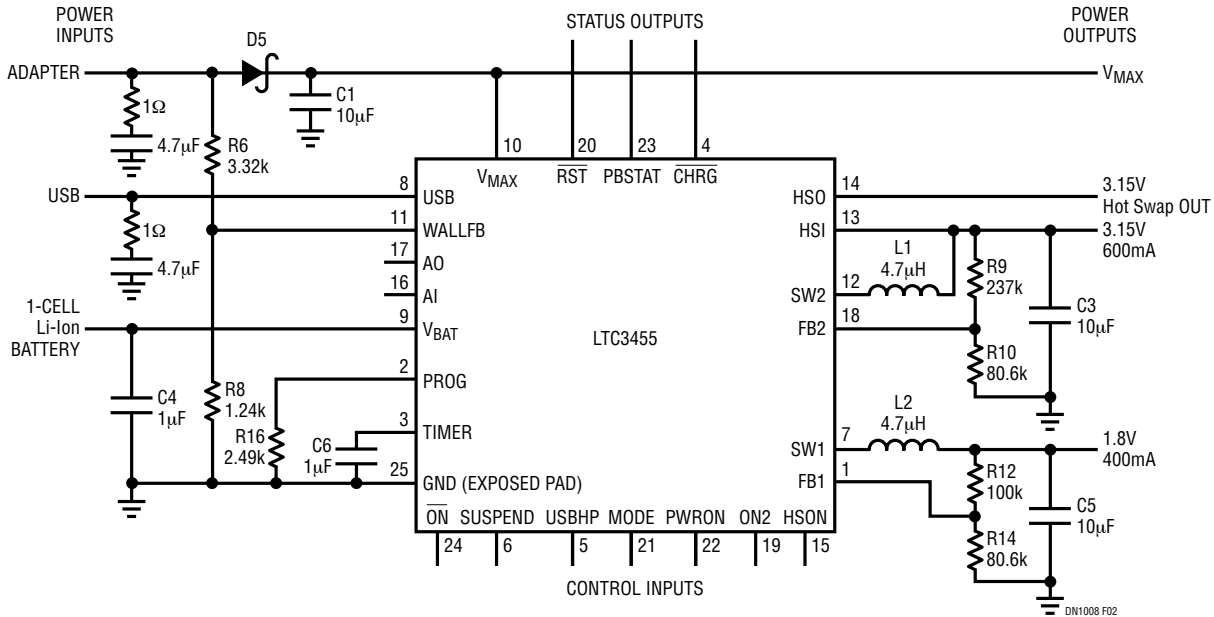

Figure 2. Minimum LTC3455 Implementation

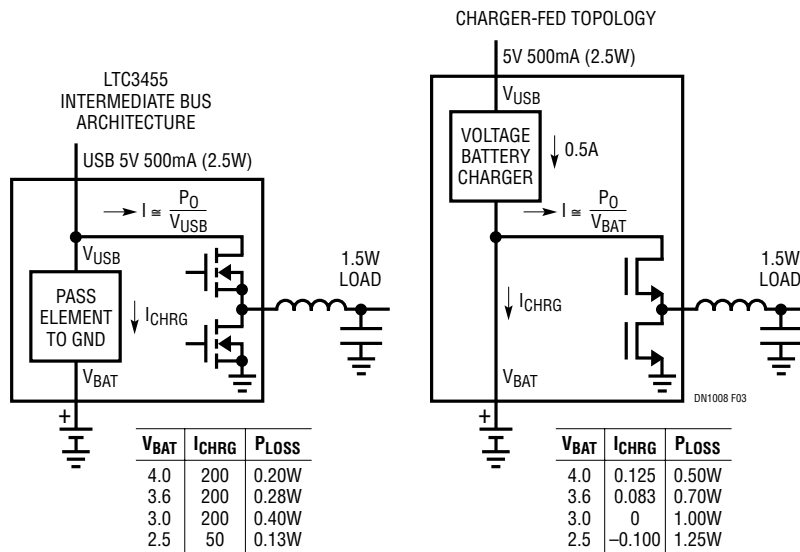

Figure 3. Charge Rate and Dissipation Advantage of Intermediate Bus vs Charger Fed Topologies

Data Sheet Download

<http://www.linear.com>

For applications help,
call (408) 432-1900, Ext. 2759